



Digital Dimmer

User's Manual

Version 1.40

CONTENTS

1. Introduction	3
2. Quick Manual / Function and Controls	4
3. Overview of Functions	5
4. The Menus	6
4.1 The Top Menu	6
4.2 The Channel Menu (2nd Menu)	7
4.3 The Memory Menu (3rd Menu)	8
4.4 The Setup Menu (Supervisor Menu)	9
4.4.1 DMX-Fail (reaction when DMX signal stops)	9
4.4.2 DMX MODE (different DMX operating modes)	9
4.4.3 DMX/MIDI (switch between DMX and MIDI)	10
4.4.4 MIDI CHANNEL	10
4.4.5 CLEAR CURVES (set curves to linear, default)	10
4.4.6 USER MODE (cut down the operation)	10
4.4.7 DELETE ALL	10
4.4.8. a. 4.4.9 CURVE USER (user definable control curves)	11
4.4.10. PHASE CORR. (activate phaseangle correction)	11
4.4.11. MASTER/SLAVE (coupling of dimmers)	11
4.4.12. UNIT NO.....	11
5. Starting the Dimmer	12
5.1 Mains Power Supply and earthing	12
5.2 Fan Control	12
5.3 Overvoltage	12
5.4 DMX Connections	13
5.5 Analogue Input (0...10 Volt)	13
6. Measures and Weights	13
7. In- and Outputs	14
7.1 DMX In- and Output	14
7.2 Analogue Input (0...10 Volt)	14
7.3 MIDI Input	14
7.4 Link In- and Output	15
7.5 Power supply	15
7.6 Load Outputs	15
8. Opening the Dimmer (Service)	16
9. Important Safety Instructions	17
10. Declaration of Conformity	18
11. Appendix	19
12. Index	20

1. Introduction

The MA DIGITAL DIMMER contains a 32 bit high power computer with a Time Processing Unit and a big graphic display in a very solid housing. This extravagant technology offers new and exciting possibilities:

- ease of operation due to few, clear menus
- free patching of the DMX addresses for every channel
- free programming of control curves
- internal storable memories with crossfade
- internal storable chase with crossfade
- stopping/failure of DMX signal can start a chase or call a memory
- possibility of cutting down the operation
- electronic fuse- and loadcheck
- overvoltage and overtemperature warning with switch off
- indication of incoming signals, phase voltage, memories, etc. by the LCD display
- several dimmers can be linked
- MIDI interface to call internal chase and memories

The MA DIGITAL DIMMER works with the phase angle control method with SCRs. This method produces disturbance especially in the lower frequency range. This will be eliminated by using very good interference suppression filters.

The heat production of the filters is reduced by using a new core material. The rest of the heat will be blown out through the front panel by a powerful temperature controlled fan.

100% duty cycle is absolutely guaranteed.

The short circuit protection for each single channel is due to high quality Siemens magnetic circuit breakers and SCRs with 1000 A peak current capacity.

Built-in DMX512, analogue input (0...10 Volt) and load outputs with a wide range of connectors allow many different applications.

2. Quick Manual / Function and Controls

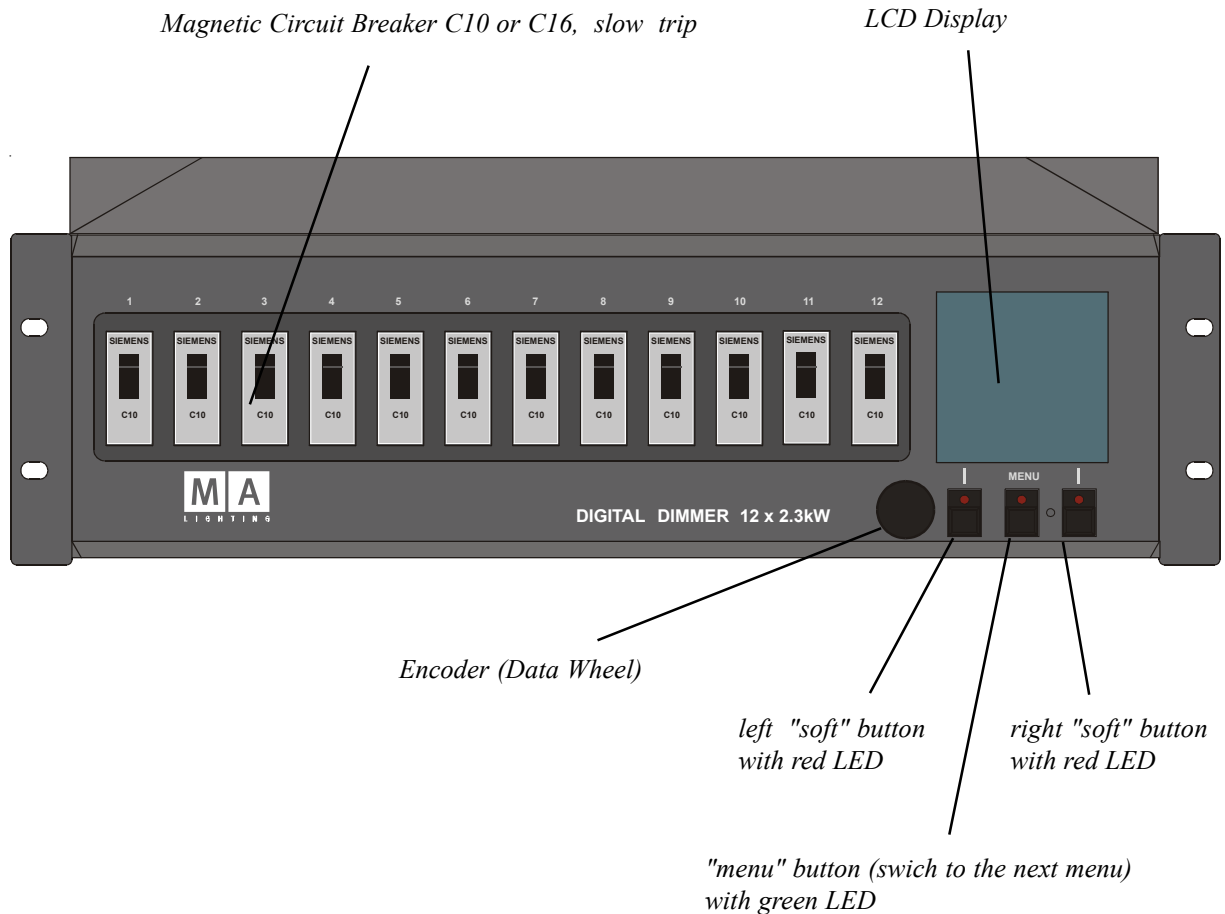

Quick Manual for people in hurry:

Before switching the dimmer on connect the load control cables.

- If the dimmer is delivered ex work and used with analogue input, it is not necessary to make any adjustments.
- If the dimmer is delivered ex work and used with DMX input, please press the Menu button (middle) under the display once. Now the channel menu appears, where the DMX start address can be set. To do that keep the right button pressed down and adjust the DMX start address with the encoder.
- If the Dimmer is not delivered ex work, but e.g. is returned from a rental, all storages should be cleared and set to default values:
To activate this powerful function please read chapter 4.4 resp. 4.4.7.

Basically the menus and softkeys work as follows:

The three "basic menus" can be selected one after the other by the middle button.

The encoder can be turned with or without simultaneously pressing a button; the functions will be different in the various menus.

Programming is only possible by pressing a button and turning the encoder at the same time.

3. Overview of Functions

This "Menu Tree" shows all possible menus.

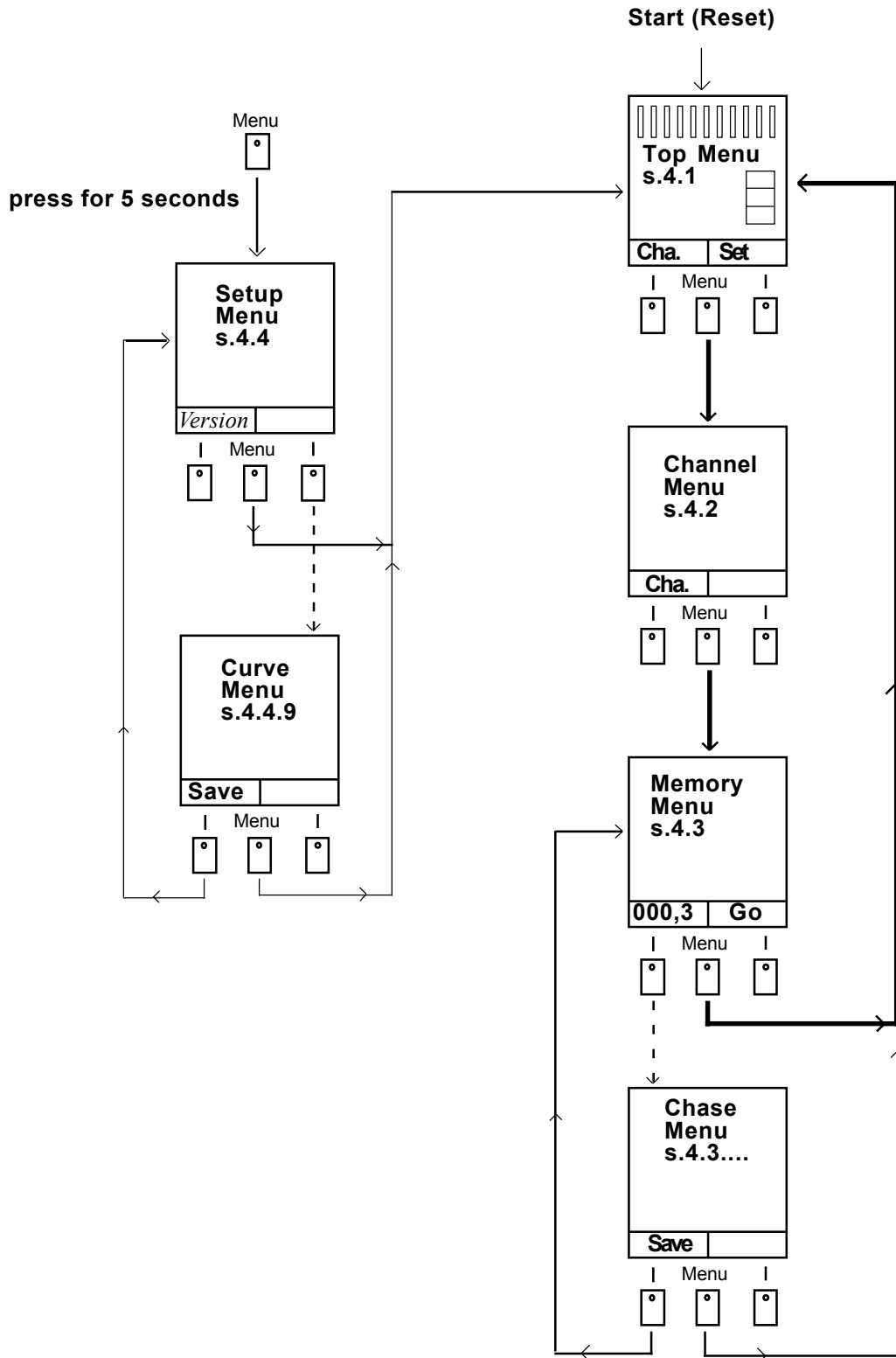

4. The Menus

The LCD display is integrated into the front panel of the Digital Dimmer.

The three buttons below the display and the Encoder (Data Wheel) make all necessary adjustments possible e.g. DMX address, limitation, control curves, preheat, etc.

Principle of working: The middle button below the Display leads to the following 3 menus. All data are fed into the dimmer by the encoder and both softkeys.

More details in the following chapters.

4.1 The Top Menu

After "Power On" the "Top Menu" is shown in the display.

This menu is the standard menu during normal use. Here the status and error messages and the input monitors of the channels are displayed.

Within this menu it is also possible to set the channels to definable values (test function).

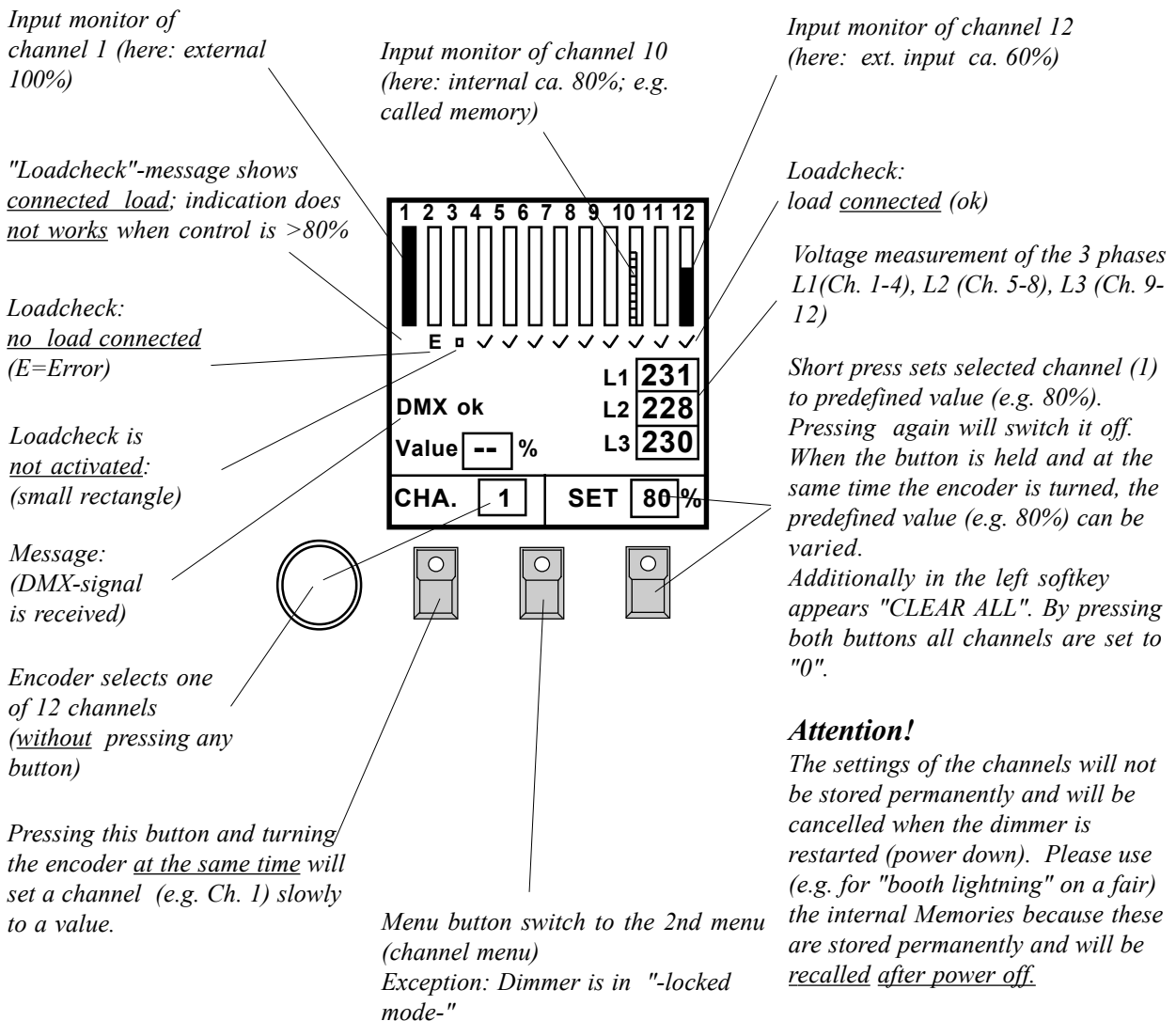

4.2 The Channel Menu (2nd Menu)

This menu always appears after the Top Menu when the middle button (Menu) is pressed. Here for every channel the DMX address, a control curve, the limitation, the preheat of the lamps and the loadcheck is programmed.

Procedure: The encoder selects one channel (1...12). In the display the cursor is moving up and down (vertically).

When the left button is pressed the encoder now works in the horizontal direction (left/right). Now "DMX address", "Curve", "Limit" etc. can be selected. The actual value is displayed inversely. So a good orientation is always ensured.

When the right button is pressed and the encoder turned simultaneously the actual value (e.g. DMX address, Switch, ...) can be changed.

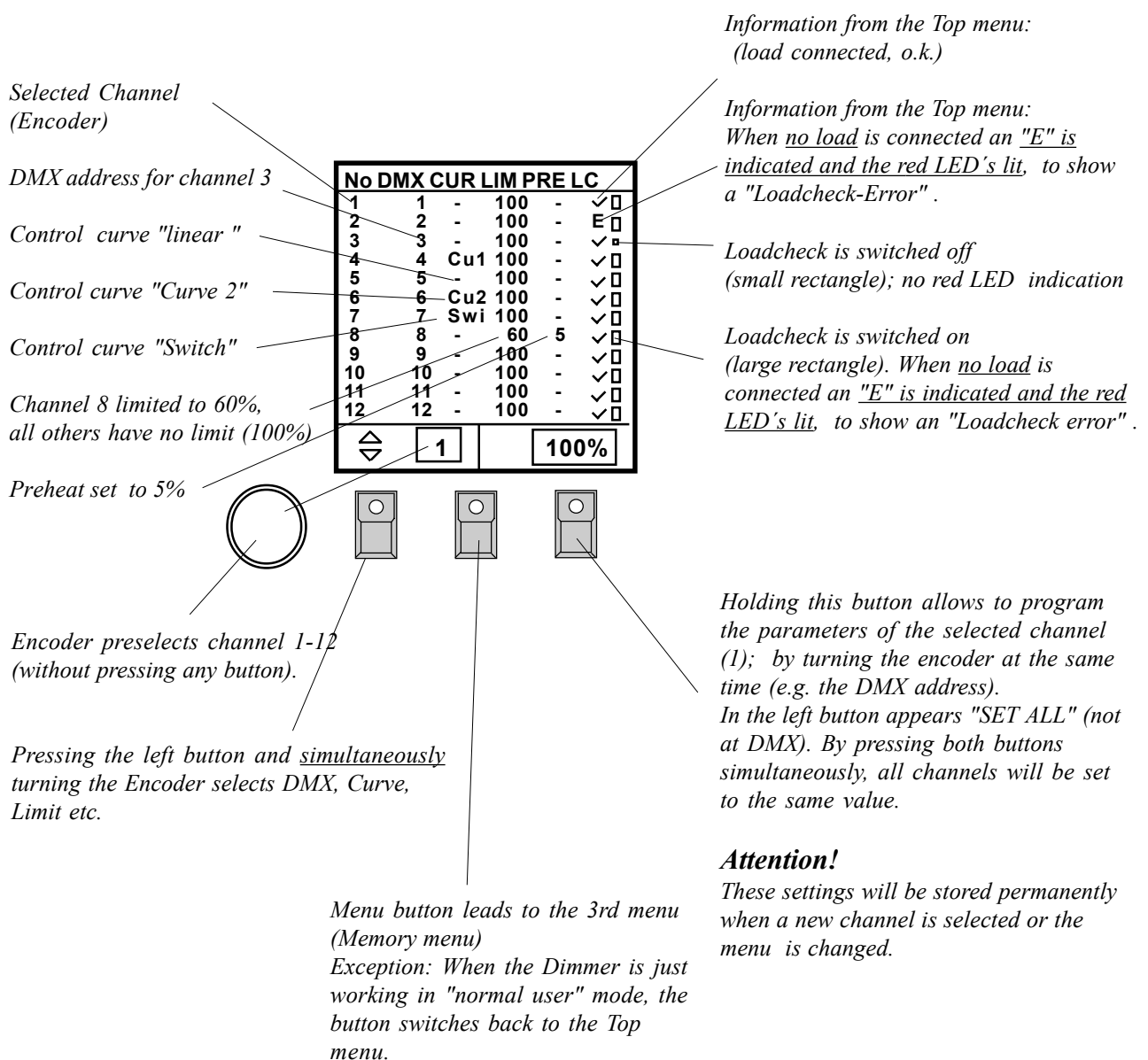

4.3 The Memory Menu (3rd Menu)

This menu appears after the channel menu, if the menu button is pressed (provided that the Supervisor mode is activated, see 4.4.6).

In this menu 12 real level memories can be stored and recalled.

Furthermore, a chase (sequence) can be started containing the internal stored memories. The running speed, fadetime and the number of steps can be programmed.

Preselect no memory or chaser "off"

Preselect chaser "on"

Preselect memory 3

Encoder selects (without pressing a button) between 12 Memories, a chase and "off" (nothing).

Pressing this button and simultaneously turning the encoder changes the crossfade time for the memories.

Exception: *The chase is selected. Now "EDIT" is displayed here.*

If now "Edit" is pressed the Chaser edit menu is displayed it is a submenu of the Memory menu. Here the 3 chaser parameter can be programmed.

- "Speed" (Steptime) 0,1...999 seconds,
- "Fade" (crossfade time) 0...100%
- "Steps" (number of steps) 0...12 ,

e.g. Steps = 3 means, that the case consist out of the first three memories.

The way to control this menu is the same as in the Channel menu (2nd menu).

"Save" returns to the Memory menu.

The "menu button" leads to the Top menu.

Programming contents of a memory
(Programming of memories :
Select a memory with the Encoder , press the left button and then also the right button, "Store"). This will store the memory permanently.

This button (Go) will recall the selected memory, chase or "Off" function (depending on the selection)
A crossfade time is activated (here 3 sec.).
Attention!
The memories or chaser will be active, until "off" or another memory is started. The activated memory will be stored permanently, when this menu is left.

Leads back to the Top menu.

4.4 The Setup Menu (Supervisor Menu)

This menu can be reached only by pressing the menu button (middle button) for a minimum of 5 seconds. In this menu very important parameters can be controlled .

Attention!

In this menu drastic changes can be made, which can alter the function of the dimmer considerably (e.g. delete all).

Controlling this menu: Turning the encoder selects the line, pressing the right button and simultaneously turning the encoder selects different functions or starts them.

All functions are permanently stored when the menu is left.

4.4.1 DMX Fail (reaction when DMX signal stops)

Here the reaction to failing DMX signal can be programmed.

- HOLD: holds the last received DMX signal until a new DMX signal reaches the dimmer.
- OFF: holds the last received DMX signal for 1 second and then switches off.
Com.: The analogue input (0...10 Volt) will be switched off, when a valid DMX signal is received.
- CHA 1s: starts the internal chase after waiting for 1 second (see 4.3).
- M1 1s: calls internal memory no.1 after waiting for 1 second.
- M2 1s: calls internal memory no.1 after waiting for 1 second.
- M3 1s: etc. etc.
- CHA 9s: starts the internal chase after waiting for 9 second's.
- M1 9s: calls internal memory no.1 after waiting for 9 second's.
- M2 9s: etc. etc.

The actual status will be displayed in the Top Menu (message: "NO DMX M01")

4.4.2 DMX MODE (different DMX operating modes)

Here "Block", "Single" and "2Cha." can be selected.

- Single means, that every dimmer channel can be patched to a freely selectable DMX address (Single-Mode, free patching).
- Block means, that the complete dimmer (12 channels) has only one start address (Block Mode). Starting with the first dimmer channel, every next channel has a DMX address which is one number higher. The "Block" mode is the standard mode (default).
- 2 Cha. means, that the 2-channel switch-mode is active. This mode is necessary, if only 2 single DMX channels control all 12 dimmer channels (switch on and off). This method economizes a lot of DMX channels.
Mode of operation: The first DMX channel switches exactly 64 different combinations of dimmer no. 1...6 on and off depending on its value. The "Binary principle" is used. The 2nd DMX channel controls the dimmer channels 6...12.
Examples and a table can be found in the appendix of this manual.

4.4.3 DMX/MIDI (switch between DMX and MIDI input)

Here the digital serial input can be selected: DMX512 or MIDI.
MIDI accepts "program change" commands 0...13. (e.g. used for a MIDI footswitch).
The program change commands call up the internal memories, chase or "OFF"
(see Memory menu 4.3).

4.4.4 MIDI CHANNEL

The MIDI channel can be selected between 1...16.

4.4.5 CLEAR CURVES (set curves to linear, default)

Deletes both free programmable control curves (set to linear) (see 4.4.8). Therefore the cursor is set on this line, the right button is pressed and the encoder turned simultaneously.

Attention! The curves will be deleted and can not be recalled! Be careful using this function, because it may be hard work to reprogram the curves.

4.4.6 USER MODE (cut down the operation of the dimmer)

With this function the dimmer function can be cut down in 3 steps:

- SUPER "Supervisor" means, that all functions can be used.
- NORM "Normal User" means, that in the Channel Menu only the DMX address can be programmed. The Memory Menu is switched off.
This mode should be used, when the dimmer must be protected but the test function must remain usable and the DMX address must be programmable. (Quick-Rental / Tour).
- LOCK The dimmer is completely locked and can not be operated with the buttons or encoder.
The middle button is an exception because it allows the entry into the Setup Menu by pressing it for 5 seconds.
Comment: The DMX as well as the analogue input works normally as before.

4.4.7 DELETE ALL (set all to default)

"Delete All" deletes all memories, chases, DMX addresses, curves, etc. The DMX address will be set to "1" and the "Block" Mode is activated. Limit is set to 100%, preheat to zero.

Attention! All data will be deleted ! Be careful in using this function, because it may be hard work to reprogram all functions.

4.4.8. and 4.4.9 CURVE USER (User definable control curves)

Here the setup menu for the control curve 1 and 2 can be activated. Individual brightness curves can be programmed, just as necessary for a lamp. Later on these curves can be assigned to the dimmer channels.

In the curve menu the encoder changes the position of the cursor in the x-axis (input); when the right button is pressed, the y-axis (output) can be modified.

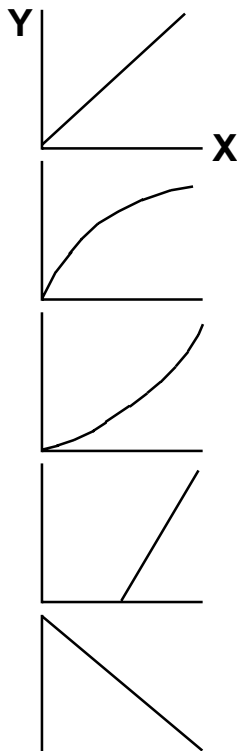

Example 1 (linear): Here the connection between input (lighting control desk) and output (lamp) is linear and 1:1. For normal use this simple curve is adequate.

Example 2 (logarithmic): The output (lamp) reacts even at low input values.

Example 3 (exponential): The output (lamp) reacts very little to small inputs, but all the more when the input is higher.

Example 4: Lamp does not react till input is at 50 % ,but in this case reacts linear.

Example 5: Lamp is controlled inversely. If the input is 0 % ,the Lamp is activated to 100 % ,if input is 100 % , the lamp is off (0%).

4.4.10. PHASE CORR. (activate phase angle correction)

Usually this control parameter is set to "ON". It makes a brightness-linear light control possible. The normal non-linearity, produced by the SRC's phase angle control, is thereby compensated. This function works in addition to the "User Curves".

This function should only be deactivated ("NO"), when this correction is made internally by the control desk (e.g. MA Lightcommander I) and cannot be switched off.

4.4.11. MASTER/SLAVE (coupling of dimmers)

For coupling several dimmers, the master and slave part can be defined. (see chap. "Connections"). There is no other effect on the dimmer.

Attention! For this function a 5 wire DIN cable must be used; MIDI cables often have only 3 wires!

4.4.12. UNIT NO. (cannot be used yet)

This parameter makes it possible to send out DMX data of the dimmer and read them externally via the DMX interface. This function will only be usable when the new DMX norm is finished. Every dimmer will then need to have its own address (unit number).

5. Starting the Dimmer

Please check all relevant safety instructions (see also Chapter 9), the EN-standards and requirements before starting the dimmer!

Additionally the local electric power company should be informed before starting dimmers with phase angle control of such power.

The MA Digital Dimmer can be built in a 19" rack mount housing (case). For additional stability horizontal bars should be used.

Phasedistribution:

12 channels: L1 = Channel 1 - 4, L2 = Channel 5 - 8, L3 = Channel 9 - 12.

6 channels: L1 = Channel 1 + 2, L2 = Channel 3 + 4, L3 = Channel 5 + 6.

The minimum load is 20Watt.

5.1 Mains Supply and earthing

The dimmer should be connected to the three phase mains power with neutral (3x230 Volt Y) via an 5 pin 63A- or 32A-CEE connector. Earth must be connected.

Color code

L1	brown
L2	black
L3	grey
N	blue
GND	green - yellow

The CEE connector is not included. The 3 phase power must be equipped with a 30mA-"Fail current protecting switch".

The dimmer can also be used in 1- and 2- phase mode at a 230 Volt mains supply. In this case the max. Load is only 40% of the normal maximum load (cable of the neutral is too thin!).

If "Socapex" connectors or "Hot-Patch-St17" connectors are used an additional Earth must be applied between dimmer and load cables or load distribution. Reason: The Socapex connector has no earth contact which is conducting at first!

After connecting and switching on no ERROR messages should show in the display; the three voltmeters should display 200-240 Volt. When one phase is lost, the green LED in the middle button will blink.

5.2 Fan Control

Please check good air-supply for the dimmer. The fan which takes the air in and transports it to the front where it is blown out is at the backside.

The fan is temperature-controlled. The first stage starts at 40 °C, the second at 50 °C.

At 80 °C the message "OVERTEMP" shows and the red LED's in the buttons will blink. Please check whether the fan is running correctly or whether the dimmer is overloaded!

When the temperature increases further, the dimmer is switched off and a beep will be started.

5.3 Overvoltage

The MA Digital Dimmer is equipped with a mains power observation.

This checks an overvoltage, which is regularly caused by exchanging phase and neutral or having lost neutral.

In this cases the power protection reacts immediately:

- All channels are switched off,
- the red LED's blink,

- a loud "Beep" starts.

If the phase and neutral are exchanged for a longer time (>15min.), the dimmer can be damaged.

5.4 DMX Connections

The DMX input and output conforms to the USITT DMX 512 (1990) standard. It is equivalent to the RS485 or RS422a norm and additionally is protected against overvoltage.

Pin layout of the 5-pin XLR jack:

Pin 1: Ground, Pin 2: Data-, Pin 3: Data+ (all Pins (1...5) are connected through)

Ground and Earth are not connected internally.

5.5 Analogue Input (0...10 Volt)

The analogue control input will be automatically switched off when DMX is fed in.

The input impedance is 50 kOhm.

The pinout of the 15 pin Sub-D connector is pin 1...12 = channel 1...12, Ground is pin 15.

Ground and Earth are not connected internally.

All other connections are described in chapter 7 (inputs and outputs).

6. Measures and Weights

Housing:	19 Inch, 3 U
Width:	483 mm (o.a.) 444 mm (inside)
Height:	132 mm
Built in depth net:	370 mm (without in- and output connectors)
Built in depth gross:	470 mm (incl. Wieland connectors, without cable)
Max. depth:	510 mm (incl. complete Wieland and handle)

The real depth varies according to the used connector, cable outlet and cable. It increases by up to 100mm.

Weight:	30 kg (2,3 kW); 35 kg (3,7 kW, 5,7 kW)
---------	--

7. In- and Outputs

7.1 DMX In- and Output

The DMX input and -output conforms to the USITT DMX 512 (1990) standard. Every unit, which works according to this norm, can control the MA Digital Dimmer.

In addition the DMX input is protected against overvoltage with suppressor diodes and conforms to the RS485 or RS 422a norm.

The DMX output is wired 1:1 (all 5 Pins) to the DMX Input.

Pinout:

pin 1 = Ground (not connected with earth)	
pin 2 = Data -	pin 4 = n.c.
pin 3 = Data +	pin 5 = n.c.

Please note that all DMX units are connected one after the other and no Y-connections are constructed. At the end of the DMX line a termination resistor between pin 2 and pin 3 (100 Ohm) must be connected.

The DMX adjustments as DMX address etc. are made in the menus (s. chapter 4.2 + 4.4)

In the dimmer the hardware is already included which makes it possible to send DMX data to be read externally via the DMX interface. But this function is only possible when the new DMX norm will be adapted. Every dimmer then will need to have its own address (unit number).

The way of working is as follows:

A light control desk or a special controller sends out a special code on the DMX line and switches its own DMX transceiver off. Then the controller switches to receive data by "listening into" the DMX line. Now the dimmer can send out its data (temperature, loadcheck, phase voltage etc.).

These can be received and evaluated by the controller.

7.2 Analogue Input (0...10 Volt)

Every light control desk which produces a control voltage of 0...10 Volt can be connected to the dimmer. Please don't forget to connect also the "ground" to pin 15.

Ground and earth are not connected and should be kept separate to avoid current loops which cause disturbance between the light control desk and the dimmer.

Earth is connected with the metal case of the Sub-D and should only be connected to the cable shield.

The input impedance is 50 kOhm.

The pinout of the 15 pin Sub-D connector is pin 1...12 = channel 1...12, Ground is pin 15.

The analogue input will be switched off automatically when DMX is received.

7.3 MIDI input

Via the MIDI input all playback functions of the memory menu can be started (OFF, Chaser and MEMORY 1...12").

Standard program change commands are accepted (0...14).

The MIDI transmitter, e.g. a MIDI footswitch, must be connected to the MIDI IN socket by using a MIDI cable. The MIDI THRU socket is necessary to send the MIDI data to further dimmers or other MIDI equipment.

7.4 Link In- and Output

Linking of dimmers is possible by using the LINK interface.

The playback functions of the Memory menu are transferred: "OFF, Chaser, MEMORY 1...12".

Other functions are not transferred.

Attention! For this function a 5 wire DIN-cable must be used; MIDI cables often have only 3 wires! This cable is connected with the MASTER dimmer (LINK-OUT) and the SLAVE dimmer (LINK-IN). The rest of the SLAVE dimmers are connected from LINK THRU to LINK IN.

Linking the dimmers is advisable when the light must be controlled only by dimmers without any other input control (e.g. if the light control desk fails). Other examples of use are test functions, focusing only with one operator and "booth lighting" at fairs.

7.5 Power Supply see chapter 5.1

7.6 Load Output

Pinout for the Wieland connectors (dimmer 12x2,3 kW, 12x3,7 kW)

top plug:	Pin 1...6	Phase 1...6	bottom plug:	Pin 1...6	Phase 7...12
	Pin 9...14	Neutral 1...6		Pin 9...14	Neutral 7...12

all Neutrals are connected inside the unit.

Pinout for the Wieland connectors (dimmer 6x5,7 kW)

top plug:	Pin 1,3,5	Phase 1...3	bottom plug:	Pin 1,3,5	Phase 4...6
	Pin 2,4,6	Neutral 1...3		Pin 2,4,6	Neutral 4...6

all Neutrals are connected inside the unit.

Pinout for the Socapex connector:

top plug:	Pin 1	Phase 1	bottom plug:	Pin1	Phase 7
	Pin 2	Neutral		Pin 2	Neutral
	Pin 3	Phase 2		Pin 3	Phase 8
	Pin 4	Neutral		Pin 4	Neutral
	Pin 5	Phase 3		Pin 5	Phase 9
	Pin 6	Neutral		Pin 6	Neutral
	Pin 7	Phase 4		Pin 7	Phase 10
	Pin 8	Neutral		Pin 8	Neutral
	Pin 9	Phase 5		Pin 9	Phase 11
	Pin 10	Neutral		Pin 10	Neutral
	Pin 11	Phase 6		Pin 11	Phase 12
	Pin 12	Neutral		Pin 12	Neutral

Earth is connected to pin 13...19 on both plugs.

Channel order of the Hot Patch Field:

View from the backside: Starting at top left, 1st and 2nd row parallel: 2 times channel one, 2x channel 2, 2x channel 3 and last in the row 2x channel 4 one on top of the other.

The 3rd and 4th row starts accordingly with 2x channel 5 etc. etc..

Warning: When Socapex and Wieland St17 connectors are used at the load output, an additional earth cable between dimmer and load cable and/or load distribution must be used. Reason: The Socapex connector has no earth contact which is conducting at first.!

At any rate the connectors should only be moved when the dimmer is switched off!

8. Opening the Dimmer (Service)

The software of the internal computer is stored in an EPROM inside of the unit. To update the software, the housing must be opened carefully.

Please follow this instructions carefully to avoid damaging the unit.

1. Pull power plug before starting to open the dimmer.

!! Very dangerous !!

2. Remove only those screws, which are really necessary to open the dimmer (see drawing).
Do not remove the 4 silver coloured slot screws at the side.
3. Do not forget to remove the knob and the small screw (M3) at the front panel.
4. Turn the dimmer on its side to make work easier.
5. Pull forward cover with front panel 3 cm to the front, then tilt the cover to the top (see drawing). This is very important, because otherwise the encoder can be damaged!
6. When the EPROM is changed, all pins must fit into the socket before the EPROM is pressed into the socket. Do not use too much force!
7. When the cover is mounted again, please be careful not to damage the encoder. Furthermore make sure the buttons can be moved easily.

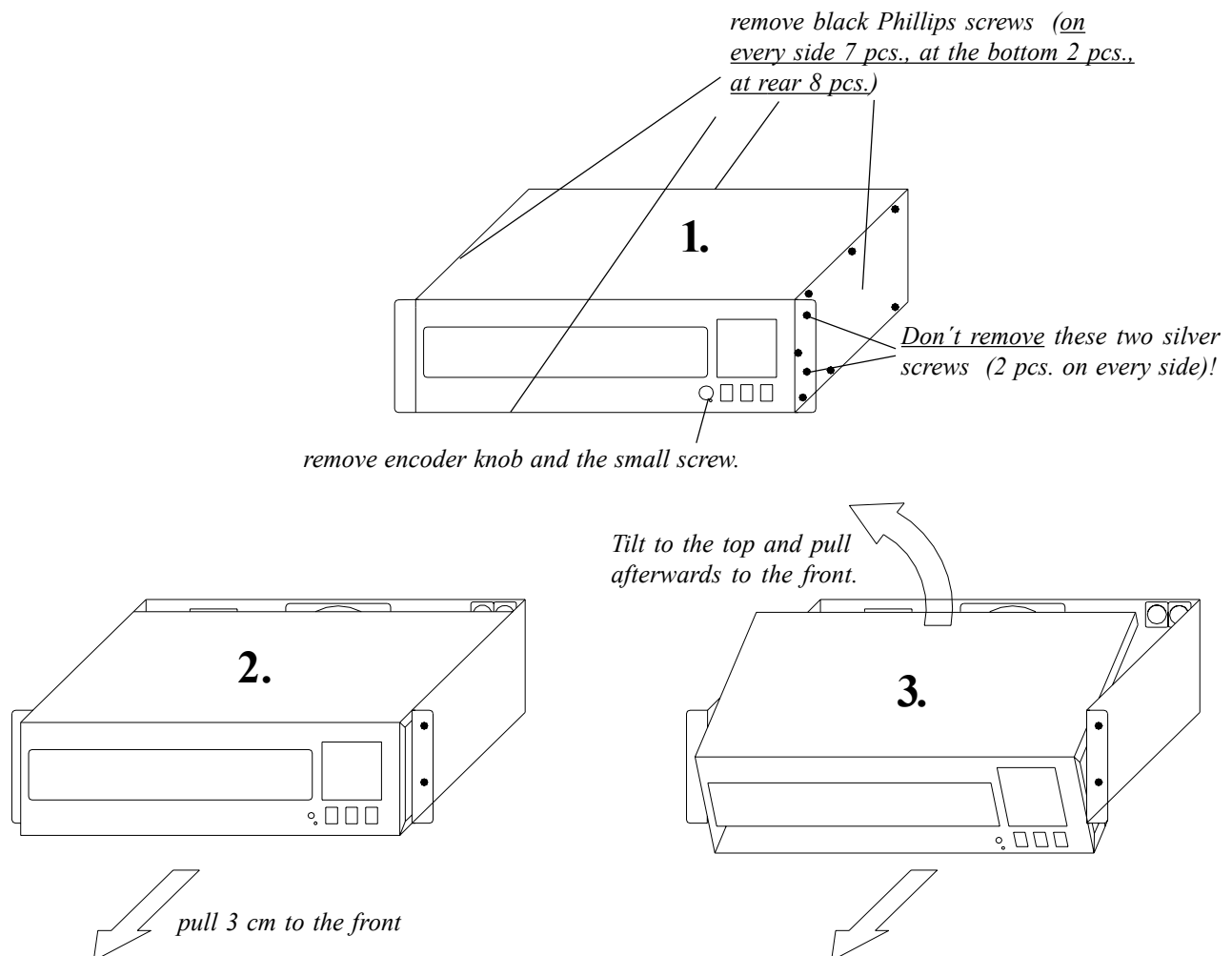

9. Safety Instructions:

1. Read all the instructions in the user's manual.
2. Keep the user's manual for later use.
3. Follow all the instructions on the unit.
4. Pull all plugs before cleaning the unit; don't use any liquid or spray cleaner. Clean with a damp cloth.
5. Don't use the unit near water.
6. Don't put the unit on unstable tables etc.. It might fall down and get damaged.
7. There are slots in the case for aeration; don't cover these slots up because they guarantee the reliable use of the unit and protect it against overheating. Don't install the unit into a frame unless sufficient aeration is guaranteed.
8. The unit is provided with a safety plug. This plug can only be used with safety sockets. These safety measures should by all means be followed. In case the plug doesn't fit into the socket (e.g. with old sockets), the socket should be replaced by an electrician.
9. Don't put any objects on the wire and make sure nobody steps on it.
10. In case you use an extension wire make sure the sum of the power consumption of the connected units does not exceed the maximum power of the wire.
11. Don't spill any liquid over the unit. Don't put any objects through the slots of the unit, as these might get in contact with parts that are live or might cause short circuits. This may cause fires and shocks.
12. Only use wires which are marked safety proof.
13. Don't use any high-power walkie-talkies near the unit.
14. Don't service the unit yourself as parts that are live might be exposed when you open the case; you run the risk of getting shocked. All services should only be carried out by a specialist.
15. If one of the following conditions occurs, please pull the plug out and call the service:
 - A. Wire or plug is damaged or worn.
 - B. Liquid got into the unit.
 - C. The unit was exposed to rain or got damp.
 - D. The unit doesn't work properly even if you follow the instructions of the user's manual.
 - E. The unit fell down and the case was damaged.

Please note! For transportation please make sure the protection is fixed!

10. DECLARATION OF CONFORMITY

according to guide lines 89/336 EEC and 92/31 EEC:

Name of producer: MA Lighting Technology GmbH
Address of producer: Dachdeckerstr. 16 D-97297 Waldbüttelbrunn Germany

declares that the product

Name of product: MA Digital Dimmer
Type: 12x2,3 kW 12x3,7 kW 6x5,7 kW

corresponds the following product specifications:

Safety: EN60065, resp. EN 60950
EMC: EN55103-1, resp. EN55103-2

Additional information:

All DMX512 and analogue inputs and outputs must be shielded and the shielding must be connected to the ground resp. to the case of the corresponding plug. Also the unit and all connected apparatus must be earthed.

Especially when Socapex or the Hot Patch Field is used, an additional earth between the dimmer housing and the load cable must be used. Generally the local electric power company should be informed before starting dimmers with phase angle control of such power.

Waldbüttelbrunn, Nov. 11st, 1995



Dipl. Ing. Michael Adenau

11. Appendix

Table for the DMX-Mode "2Cha." -binary principle-

Channel 1...6	DMX value in %	Channel 1...6	DMX value in %
000000	0 % (0.0000 % ... 1.5625 %)	000001	51 % (50.0000 % ... 51.5625 %)
100000	2 % (1.5625 % ... 3.1250 %)	100001	52 % (51.5625 % ... 53.1250 %)
010000	4 % (3.1250 % ... 4.6875 %)	010001	54 % (53.1250 % ... 54.6875 %)
110000	5 % (4.6875 % ... 6.2500 %)	110001	55 % (54.6875 % ... 56.2500 %)
001000	7 % (6.2500 % ... 7.8125 %)	001001	57 % (56.2500 % ... 57.8125 %)
101000	8 % (7.8125 % ... 9.3750 %)	101001	59 % (57.8125 % ... 59.3750 %)
011000	10 % (9.3750 % ... 10.9375 %)	011001	60 % (59.3750 % ... 60.9375 %)
111000	12 % (10.9375 % ... 12.5000 %)	111001	62 % (60.9375 % ... 62.5000 %)
000100	13 % (12.5000 % ... 14.0625 %)	000101	63 % (62.5000 % ... 64.0625 %)
100100	15 % (14.0625 % ... 15.6250 %)	100101	65 % (64.0625 % ... 65.6250 %)
010100	16 % (15.6250 % ... 17.1875 %)	010101	66 % (65.6250 % ... 67.1875 %)
110100	18 % (17.1875 % ... 18.7500 %)	110101	68 % (67.1875 % ... 68.7500 %)
001100	20 % (18.7500 % ... 20.3125 %)	001101	70 % (68.7500 % ... 70.3125 %)
101100	21 % (20.3125 % ... 21.8750 %)	101101	71 % (70.3125 % ... 71.8750 %)
011100	23 % (21.8750 % ... 23.4375 %)	011101	73 % (71.8750 % ... 73.4375 %)
111100	24 % (23.4375 % ... 25.0000 %)	111101	74 % (73.4375 % ... 75.0000 %)
000010	26 % (25.0000 % ... 26.5625 %)	000011	76 % (75.0000 % ... 76.5625 %)
100010	27 % (26.5625 % ... 28.1250 %)	100011	77 % (76.5625 % ... 78.1250 %)
010010	29 % (28.1250 % ... 29.6875 %)	010011	79 % (78.1250 % ... 79.6875 %)
110010	30 % (29.6875 % ... 31.2500 %)	110011	80 % (79.6875 % ... 81.2500 %)
001010	32 % (31.2500 % ... 32.8125 %)	001011	82 % (81.2500 % ... 82.8125 %)
101010	34 % (32.8125 % ... 34.3750 %)	101011	84 % (82.8125 % ... 84.3750 %)
011010	35 % (34.3750 % ... 35.9375 %)	011011	85 % (84.3750 % ... 85.9375 %)
111010	37 % (35.9375 % ... 37.5000 %)	111011	87 % (85.9375 % ... 87.5000 %)
000110	38 % (37.5000 % ... 39.0625 %)	000111	88 % (87.5000 % ... 89.0625 %)
100110	40 % (39.0625 % ... 40.6250 %)	100111	90 % (89.0625 % ... 90.6250 %)
010110	41 % (40.6250 % ... 42.1875 %)	010111	91 % (90.6250 % ... 92.1875 %)
110110	43 % (42.1875 % ... 43.7500 %)	110111	93 % (92.1875 % ... 93.7500 %)
001110	45 % (43.7500 % ... 45.3125 %)	001111	95 % (93.7500 % ... 95.3125 %)
101110	46 % (45.3125 % ... 46.8750 %)	101111	96 % (95.3125 % ... 96.8750 %)
011110	48 % (46.8750 % ... 48.4375 %)	011111	98 % (96.8750 % ... 98.4375 %)
111110	49 % (48.4375 % ... 50.0000 %)	111111	FF % (98.4375 % ..100.0000 %)

12. Index

2-channel-switch-mode 9, 19
2Cha.-mode-table 19

A

Acoustic signal 12
Air Condition 12

B

Binary principle 9, 19
Block Mode 9
Brightness Curves 11

C

CHA 1s 9
Channel Menu 7
CLEAR CURVES 10
Contents 2
Coupling 11, 15
Crossfade Time 8
Curve 7
CURVE USER 11

D

Definable control curves 11
DELETE ALL 10
Declaration of Conformity 18
DIN-cable 11
Display 4
DMX 13
DMX-Address 7, 9
DMX-Fail 9
DMX/MIDI 10

E

Encoder 4, 6, 9
EPROM 16
Earth 12

F

Fan Control 12
FI-Protection 12

G

Go button 8

H

HOLD 9

I

Input Impedance 13
Input Monitoring 6
Introduction 3

L

Limit 7
Link 11, 15
Loadcheck 6
Loadcheck switched off 7
Loadcheck activated 7
Locked 6

M

Mains Supply 12
Measures 13
MASTER/SLAVE 11
Memory call up 8
Memory Menu 8
Menu button 6
Menu tree 5
MIDI 10
MIDI cable 15
Minimum load 12

N

Neutral 12

O

Open the dimmer 16

P

Patch field (hot) 15
PHASE CORR. 11
Phase correction 11
Preheat 7
Program change 10
Programming of memories 8
Preheat 7
Quick Manual 4

R

Red LED's 7, 12

S

Setup Menu 9
Safety Instructions 17
Single 9
Socapex 15
Speed 8
Supervisor Menu 9

T

Top Menu 6

U

UNIT NO. 11
USER MODE 10

V

Voltage Indicator 6, 12

W

Waiting time 9
Weights 13
Wieland 15

X

X-Axis, Curve Menu 11

Y

Y-Axis, Curve Menu 11